

Allgemeine bauaufsichtliche Zulassung

Zulassungsstelle für Bauprodukte und Bauarten

Bautechnisches Prüfamt

Eine vom Bund und den Ländern
gemeinsam getragene Anstalt des öffentlichen Rechts

Mitglied der EOTA, der UEAtc und der WFTAO

Datum:

11/12/2014

Geschäftszeichen:

II 78-1.72.1-1/13

Zulassungsnummer:

Z-72.1-1

Geltungsdauer

vom: **11 December 2014**

bis: **11 December 2019**

Antragsteller:

RENOLIT Belgium N.V

Industriepark de Bruwaan

9700 OUDENAARDE

BELGIUM

Zulassungsgegenstand:

**RENOLIT-ALKORSOLAR fastening system for solar panels for use on ALKORPLAN F 35176
roof waterproofing sheets**

The subject of approval named above is herewith granted an *allgemeine bauaufsichtliche Zulassung* ('national technical approval').

This *allgemeine bauaufsichtliche Zulassung* ('national technical approval') contains twelve pages and seven annexes.

Translation authorized by DIBt

DIBt

I GENERAL PROVISIONS

- 1 With the *allgemeine bauaufsichtliche Zulassung* ('national technical approval') the fitness for use and the applicability of the subject of approval in accordance with the *Landesbauordnungen* ('Building Regulations of the Land') have been verified.
- 2 If in the *allgemeine bauaufsichtliche Zulassung* ('national technical approval') requirements are made concerning the special expertise and experience of persons entrusted with the manufacture of construction products and types of construction in accordance with the relevant regulations of the Land following section 17, sub-section 5, of the *Musterbauordnung* ('Model Building Code'), it shall be noted that this expertise and experience can also be proven by equivalent verifications from other Member States of the European Union. If necessary, this also applies to verifications presented within the framework of the Agreement on the European Economic Area (EEA) or other bilateral agreements.
- 3 The *allgemeine bauaufsichtliche Zulassung* ('national technical approval') does not replace the permits, approvals and certificates prescribed by law for carrying out building projects.
- 4 The *allgemeine bauaufsichtliche Zulassung* ('national technical approval') will be granted without prejudice to the rights of third parties, in particular private property rights.
- 5 Notwithstanding further regulations in the 'Specific Provisions', manufacturers and distributors of the subject of approval shall make copies of the *allgemeine bauaufsichtliche Zulassung* ('national technical approval') available to the user and point out that the *allgemeine bauaufsichtliche Zulassung* ('national technical approval') shall be available at the place of use. Upon request copies of the *allgemeine bauaufsichtliche Zulassung* ('national technical approval') shall be placed at the disposal of the authorities involved.
- 6 The *allgemeine bauaufsichtliche Zulassung* ('national technical approval') may be reproduced in full only. Partial publication requires the consent of Deutsches Institut für Bautechnik. Texts and drawings of advertising brochures may not be in contradiction to the *allgemeine bauaufsichtliche Zulassung* ('national technical approval'). Translations of the *allgemeine bauaufsichtliche Zulassung* ('national technical approval') shall contain the note 'Translation of the German original, not checked by Deutsches Institut für Bautechnik'.
- 7 The *allgemeine bauaufsichtliche Zulassung* ('national technical approval') is granted until revoked. The provisions of the *allgemeine bauaufsichtliche Zulassung* ('national technical approval') can subsequently be supplemented and amended, in particular if this is required by new technical findings.

II SPECIFIC PROVISIONS

1 Subject of approval and field of application

1.1 Subject of approval

(1) The subject of approval is the 'RENOLIT-ALKORSOLAR fastening system' (hereinafter referred to as the 'fastening system') comprising:

- aluminium profile,
- ALKORPLAN plastic profile and
- EJOT JT3-2-6.0 self-drilling screw (mounting screw).

(2) The fastening system shall exclusively be used on the mechanically fastened ALKORPLAN F 35176 roof waterproofing sheet (hereinafter referred to as the 'waterproofing sheet'). The system design is shown in Annex 1.

(3) For use of the fastening system, the substrate (roof structure) shall meet certain requirements, e.g. pertaining to roof surface and slope, type and spacing of waterproofing sheet fasteners, type and geometry of the insulation product, in accordance with this *allgemeine bauaufsichtliche Zulassung* ('national technical approval').

(4) The fastening system shall exclusively be used for solar panels installed parallel to the roof surface.

(5) The fastening system transmits wind loads acting vertically (vertical wind suction action) on the roof surface to the substrate (roof structure). Transmission of horizontal forces shall be ensured through additional measures.

2 Provisions concerning construction products

2.1 Properties and composition

2.1.1 General

(1) The material characteristics of the waterproofing sheet and the plastic profile were determined in accordance with the *DIBt-Prüfplan zur Ermittlung statischer Kennwerte von Dachabdichtungsbahnen unter Berücksichtigung von Beständigkeit und Dauerhaftigkeit* ('DIBt test plan for determination of structural characteristics of waterproofing sheets taking stability and durability into account')¹.

(2) The fastening system was tested and evaluated in accordance with the *DIBt-Prüfplan für Befestigungen von Anlagen und Elementen auf Dachabdichtungen* ('DIBt test plan for fasteners for systems and elements on waterproofing sheets')².

2.1.2 Waterproofing sheet

(1) The waterproofing sheet consists of plasticised polyvinyl chloride (PVC-P) with synthetic fibre reinforcement in accordance with DIN EN 13956³ with the composition deposited with DIBt.

(2) The main performance characteristics and additional properties shall correspond to the information provided in Annex 2.

(3) The waterproofing sheet shall meet the requirements of DIN V 20000-2014⁴, section 5.2.3.1, table 16.

¹ available from DIBt
² available from DIBt
³ DIN EN 13956
⁴ DIN V 20000-2014

Flexible sheets for waterproofing - Plastic and rubber sheets for roof waterproofing
Application of construction products in structures - Part 201: Application standard for flexible sheets for waterproofing according to European product standards for the use as waterproofing of roofs

2.1.3 Components of the fastening system

2.1.3.1 Aluminium profile

The hollow aluminium profiles in accordance with EN 12020-2⁵ are composed of the aluminium alloy T6-ALMg0.7Si in accordance with EN-AW 6063⁶ and DIN EN 573-3⁷. The geometry and other properties correspond to the information provided in Annex 3, figure 1 and Annex 4.

2.1.3.2 Plastic profile

The plastic profile is composed of extruded plasticised polyvinyl chloride (PVC-P) in accordance with the composition deposited with DIBt. The profile is composed of a square hollow profile with moulded weld neck flanges. The dimensions and additional characteristics correspond to the information provided in Annex 3, figure 2 and Annex 4.

2.1.3.3 Mounting screw

The EJOT JT3-2-6.0 self-drilling screw in accordance with *allgemeine bauaufsichtliche Zulassung* ('national technical approval') no. Z-14.4-426 shall be used as a mounting screw for fastening the solar system substructure in the aluminium profile in accordance with the provisions of Annex 1 and table 1 of Annex 4.

2.1.4 Fastening system

(1) The design of the fastening system shall correspond to the information provided in Annexes 1 and 5.

(2) Vertical wind suction loads shall be transmitted via the fastening system and the waterproofing sheet to the load-bearing components in accordance with the selected axis spacing of the profiles and the fasteners.

2.2 Production, delivery, storage and marking

2.2.1 Production, delivery, storage

(1) The manufacture or tailoring of the plastic profile shall be carried out in accordance with the formulation/composition deposited with DIBt in the manufacturing plant of RENOLIT Belgium N.V., Industriepark de Bruwaan, 9700 Oudenaarde, Belgium, from the starting powder mixture using the extrusion process.

(2) The ALKORPLAN F 35176 waterproofing sheet shall be manufactured in accordance with the provisions of EN 13956.

(3) The aluminium profile shall be manufactured in accordance with the provisions of this approval and the requirements of the approval holder.

(4) The mounting screws shall be manufactured in accordance with *allgemeine bauaufsichtliche Zulassung* ('national technical approval') no. Z-14.4-426.

(5) The fastening system with its components plastic profile, aluminium profile and mounting screw shall be assembled in the manufacturing plant of RENOLIT Belgium N.V., Industriepark de Bruwaan 9700 Oudenaarde, Belgium (hereinafter referred to as the 'approval holder').

(6) Any changes require prior approval from Deutsches Institut für Bautechnik.

(7) The fastening system shall be delivered in complete form with all components with a suitable transport vehicle.

⁵	DIN EN 12020-2:2008	Aluminium and aluminium alloys – Extruded precision profiles in alloys EN AW-6060 and EN AW 6063 – Part 2 Tolerances on dimensions and form
⁶	EN-AW 6063:2011-07	Aluminium material data sheet, EN AW-Al Mg0.7Si
⁷	DIN EN 573-3:2013	Aluminium and aluminium alloys - Chemical composition and form of semi-finished product - Part 3: Chemical composition and form of products

(8) Storage prior to installation shall be carried out so that the serviceability is not affected. In particular, all components shall be stored in their unopened original packaging and be protected from moisture and frost. Additional instructions from the component manufacturers shall be observed.

2.2.2 Marking

(1) The delivery note for the fastening system shall be marked by the approval holder with the conformity mark ('Ü mark') in accordance with the conformity marking regulations of the Länder. The mark of conformity may only be applied if the requirements for attestation of conformity given in section 2.3 are met.

(2) The plastic profiles shall be marked with:

- the factory symbol,
- the date of manufacture (month and year) and
- 'Part of the RENOLIT-ALKORSOLAR fastening system in accordance with Z-72.1-1',

e.g.: '*Factory symbol* 1014 Part of the RENOLIT-ALKORSOLAR fastening system in accordance with Z-72.1-1.

(3) The delivery note for the fastening system shall contain the following information:

- full designations of the individual components
- 'RENOLIT-ALKORSOLAR fastening system for solar panels in accordance with *allgemeine bauaufsichtliche Zulassung* ('national technical approval') no. Z-72.1-1'
- name and factory symbol of the approval holder
- date of manufacture.

2.3 Certificate of conformity for the construction product

2.3.1 General

(1) The attestation of conformity of the fastening system with the provisions of this *allgemeine bauaufsichtliche Zulassung* ('national technical approval') shall be issued for every manufacturing plant in the form of a certificate of conformity based on factory production control and regular external surveillance, including initial type-testing of the finished parts, in accordance with the following provisions.

(2) To issue the certificate of conformity and for external surveillance, including the associated product-testing to be carried out in the process, the manufacturer of the finished parts shall use an appropriately accredited certification body and an appropriately accredited inspection body.

(3) The approval holder shall declare that a certificate of conformity has been granted by affixing a conformity mark ('Ü mark') to the plastic profile as a component of the fastening system and the fastening system itself stating their intended use.

(4) A copy of the certificate of conformity issued by the certification body shall be sent to Deutsches Institut für Bautechnik and the supreme building supervisory authority of the Land in which the relevant manufacturing plant is located.

(5) A copy of the initial type-testing evaluation report shall also be sent to Deutsches Institut für Bautechnik.

2.3.2 Factory production control

(1) A factory production control system shall be set up and implemented in the manufacturing plant of the fastening system. Factory production control is understood to be continuous surveillance of production by the manufacturer to ensure that the manufactured construction products satisfy the provisions of this *allgemeine bauaufsichtliche Zulassung* ('national technical approval').

(2) Factory production control shall be carried out in accordance with Annex 6.

(3) The results of the factory production control shall be recorded and evaluated. The records shall at least include the following information:

- designation of the construction product or the starting material and the constituents,
- type of inspection or test,
- date of manufacture and testing of the construction product or the starting material or the constituents,
- results of inspection and tests and, where applicable, comparison with requirements and
- signature of the person responsible for factory production control.

(4) The records shall be kept for at least five years and be submitted to the inspection body in charge of external surveillance. They shall be submitted to Deutsches Institut für Bautechnik and the competent supreme building supervisory authority upon request.

(5) If the test result is not satisfactory, the person responsible for the factory production control shall immediately take the necessary measures to remedy the deficiencies. Construction products which do not meet the requirements shall be handled in such a manner that they cannot be confused with compliant products. After the defect has been remedied the relevant test shall be repeated immediately - where technically practicable and necessary for demonstration that the defect has been eliminated.

2.3.3 External surveillance

(1) In the manufacturing plant, factory production control shall be checked regularly at least twice a year by means of external surveillance. If it is verified through at least two successive external surveillance audits that the fastening systems meet the requirements of the approval, the frequency of external surveillance may be reduced to once a year. If the results are unsatisfactory with annual surveillance audits, the sampling and auditing interval shall revert back to every six months.

(2) Initial type-testing of the fastening system shall be carried out within the scope of external surveillance. Samples for random testing may also be taken. Sampling and testing shall be the responsibility of the recognised inspection bodies.

(3) The following properties and characteristics shall be determined through carrying out individual tests in accordance with the information provided in table 2 of Annex 2 and Annex 6 during **initial type-testing** of the fastening system:

(4) These tests may be dropped if the usability tests carried out for the *allgemeine bauaufsichtliche Zulassung* ('national technical approval') were conducted on official samples taken from ongoing production.

(5) **External surveillance** shall be carried out in accordance with the information provided in Annex 6.

(6) The results of certification and external surveillance shall be kept for at least five years. The certification body or inspection body shall present them to Deutsches Institut für Bautechnik and the competent supreme building authority upon request.

3 Provisions for design and structural analysis

3.1 Design

(1) The design of the fastening system for solar systems shall be planned and verified taking into account the relevant standard engineering practices as well as statutory requirements.

(2) The planning of the fastening system for solar systems on the mechanically fastened waterproofing sheet shall only be carried out by expert planners. Checkable design and layout drawings for the fastening of the solar panels shall be prepared taking into account the expected installation conditions.

(3) The fastening system shall only be planned for the designated mechanically fastened waterproofing sheet which has been designed and processed in accordance with DIN 18531⁸ with the components specified in this approval.

(4) For the function of the roof waterproofing sheet the planning principles corresponding to DIN 18531, in particular regarding roof slope, unimpeded water drainage and accessibility for waterproofing maintenance, shall be considered. In particular, the expert planner shall determine the minimum compressive strength of the insulation product required for ensuring that any locally increased compressive stresses resulting from erection can be transmitted to the substrate without causing any damage.

(5) The verification of the ultimate limit state for load-bearing capacity shall be provided for each solar system mounting on a mechanically fastened waterproofing sheet.

(6) The provisions of the *allgemeine bauaufsichtliche Zulassung* ('national technical approval') for the EJOT self-drilling screw (mounting screw) shall be complied with.

(7) The mechanical fastening of the waterproofing sheet shall be dimensioned independently of the solar installation to ensure that it is stable even without the solar installation.

(8) In addition to the provisions in this approval, a structural analysis shall be carried out to verify the increased load on the building caused by the weight of the solar installation .

(9) The fastening of the solar system shall only be carried out on roof superstructures with mechanically fastened roof waterproofing sheets possessing at least the following prerequisites:

- The waterproofing of the roof has been carried out in accordance with DIN 18531.
- The time period between installation of the waterproofing sheet and installation of the solar system is less than one year.
- The roof slope is less than 5°.
- The insulation product has a sufficient compressive strength.
- The fasteners used to fasten the waterproofing sheet and their marking correspond to the respective usability verifications.
- The requirements regarding spacing and number of fasteners for the waterproofing sheet are yielded from the dimensioning carried out in accordance with section 3.2.
- The waterproofing sheet shall be free of damage and impermissible soiling. The surface of the waterproofing sheet shall be cleaned as required and pretreated when necessary in accordance with the approval holder's specifications.

(10) The plastic profiles shall be arranged adjacent to a row of fasteners. Should the plastic profile not be situated next to a weld seam, the waterproofing sheet shall be fastened mechanically by means of an additional row of fasteners.

(11) The solar installation (module or fastening system) shall be at least 500 mm from the edge of the roof.

⁸

DIN 18531:2010 05

Waterproofing of roofs - Seals for non-utilised roofs -

3.2 Dimensioning

3.2.1 General

(1) Unless otherwise specified in the following sections, all required structural verifications shall be provided based on the technical building regulations officially introduced in the field of construction.

(2) When dimensioning the fastening system for the solar system the weight of the solar system may be taken into account.

(3) The verification applies exclusively to uplift vertical forces resulting from wind loads. Any occurring horizontal forces shall be absorbed using suitable additional measures.

(4) The stability shall be verified for the ultimate limit state for load-bearing capacity

$$E_d \leq R_d.$$

E_d : design value of the action

R_d : design value of the structural resistance for verification of the ultimate limit state for load-bearing capacity

(5) In the planning of the solar installation, the possibility of an approx. 2 cm vertical uplift of the profiles at the design wind load shall be taken into consideration.

(6) The verification shall be provided for the connection of the waterproofing sheet to the fastening element as well as the fastener. Verification for the other components of the fastening system (plastic profile, aluminium profile and mounting screw) and the waterproofing sheet as well as the interplay between them for fastening of the solar system is thus provided.

3.2.2 Design values for actions E_d

(1) The characteristic values for the actions E_k , the partial safety factors γ_F and the combination coefficients ψ shall be taken from the technical building regulations officially introduced in the field of construction;

(2) The design value of the action is yielded from the characteristic values of the actions taking into account the partial safety factors.

For the dimensioning of the fastening system for the solar system the aerodynamic coefficients of the wind suction in accordance with DIN EN 1991-1-4⁹ may be used. However, a net pressure coefficient of at least $c_{P,net} = -0.7$ shall be applied.

Moreover, the wind suction and wind pressure shall be verified in accordance with section 1.5 of DIN EN 1991-1-4/NA¹⁰.

(3) For the wind and temperature effects to be considered in the load case 'summer' the ψ coefficient defined in DIN EN 1990/NA may be applied. In the design situation in which the wind is considered to be the dominant variable action, the ψ coefficient may be considered in the design value of the structural resistance R_d (see section 3.2.3).

⁹ DIN EN 1991-1-4:2005 + A1:2010 + AC:2010 Eurocode 1: Actions on structures - Parts 1-4: General actions - wind actions

¹⁰ DIN EN 1991-1-4:2010/12 National annex - Nationally determined parameters - Eurocode 1: Actions on structures - Parts 1-4: General actions - Wind actions

3.2.3 Design value for structural resistance R_d

(1) The design value of structural resistance R_d is yielded from the characteristic value R_k in consideration of the material safety factor γ_M , the ageing factor K_A and the ambient temperature factor K_T as follows:

$$R_d = \frac{R_k}{\gamma_M * K_A * K_T}$$

R_k : system-specific characteristic value of structural resistance of the connection between the waterproofing sheet and the fastener, $R_k = 1.0$ kN/fastener

γ_M	material safety factor		1.3
K_A	reduction factor for ageing		1.05
K_T	reduction factor for ambient temperature	summer ($\psi = 100\%$)	1.3
		summer ($\psi = 60\%$)	1.18
		winter	1.0

(2) In the design situation in which the wind is considered to be the dominant variable action, the reduction in structural resistance due to temperature may be reduced by means of the ψ coefficient for the summer load case. For this design situation, a reduction factor for the ambient temperature of $1 + (K-1.0) * \psi$ may be applied.

The verification shall be made for all design situations:

Summer load case 1: $K_{t,summer} (\psi = 100\%)$ in combination with 60% wind load

Summer load case 2: $K_{t,summer} (\psi = 60\%)$ in combination with 100% wind load

Winter load case: $K_{t,winter}$ in combination with 100% wind load

(3) The characteristic value of the pullout force of the fastener and the associated safety factors and reduction values shall be taken from the respective approval.

4 Provisions for execution

4.1 Installation

(1) The installation of the fastening system may only be carried out by companies with suitably qualified construction personnel. In addition, these companies (including their specialised staff) shall be trained in and authorised to carry out the aforementioned activities by the approval holder.

(2) For the proper fastening of a solar system the approval holder shall draw up installation and assembly instructions.

(3) The conditions of installation given in the *allgemeine bauaufsichtliche Zulassung* ('national technical approval') and by the approval holder shall be complied with.

(4) The complete set of object-specific planning documents in accordance with section 3 (e.g. dimensioning, technical drawings, layout drawings or installation plans) from which the type, number, distribution and spacing of the fasteners as well as of the associated washers and the minimum required compressive strength of the insulation product can be derived shall be submitted to the installing company.

(5) The fastening system shall be installed in accordance with the design documents prepared in accordance with section 3, the ultimate limit state and serviceability limit state verifications and the installation and assembly instructions of the approval holder in consideration of the specifications of this approval.

(6) Prior to installation of the fastening system the existing roof structure shall be converted to a suitable condition for the fastening system through appropriate measures. The installed insulation layer shall be checked for suitability of its compressive strength. It shall be ensured that the type, distribution, arrangement and number of fasteners for the waterproofing sheet correspond to the structural design. Fasteners may be supplemented retroactively where necessary.

(7) The fastening system shall be installed manually. Hot gas welding equipment is used for welding the plastic profiles on to the waterproofing sheet. The welding work is carried out following DVS 2225¹¹.

(8) Damaged fastening system components shall not be processed.

(9) The individual components of the fastening system shall be assembled to form the complete system in accordance with this approval taking into account the installation and assembly instructions of the approval holder.

(10) The aluminium profile shall not protrude from the plastic profile and shall be shortened where necessary.

(11) The installing company shall hand over to the operator of the installation a copy of the *allgemeine bauaufsichtliche Zulassung* ('national technical approval') as well as the installation and assembly instructions of the approval holder.

4.2 Inspection of the execution

(1) A check to determine that the declared waterproofing sheet performance data at least comply with the requirements given in table 1 of Annex 2 shall be carried out. If the declared performance does not completely cover the values, an inspection certificate shall be demanded and checked.

(2) A check to ensure that the correct components of the fastening system, e.g. EJOT self-drilling screw (mounting screw), with the respectively relevant applicability verification have been delivered to the site shall be carried out. The provisions of the respective applicability verification shall apply to the use of these construction products.

(3) Before and during installation of the fastening system the following shall be checked in particular:

- The insulation product shall exhibit a compressive strength corresponding to the planning requirements.
- The roofing sheet shall be laid in accordance with the specifications of DIN 18531. All weld seams shall be watertight over their entire lengths.
- The type, distribution and arrangement of fasteners shall correspond to the structural design data.
- The plastic profile shall be welded on to the waterproofing sheet on both sides over the entire length.
- The aluminium profile end shall be flush with the plastic profile end.
- The cross beams of the solar module substructure shall be anchored with two mounting screws each in the aluminium profile.

¹¹

DVS 2225-1:1991-02	Joining of lining membranes made from polymeric materials (geomembranes) in geotechnical and hydraulic application; welding, bonding by adhesives, vulcanising
DVS 2225-2:1992-08	Joining of lining membranes made from polymer materials in geotechnical and hydraulic engineering – site testing
DVS 2225-3:1997-07	Joining of sealing sheets made of polymeric materials in earthwork and water engineering – Requirements on welding machines and welding devices

(4) During installation, records of the verification of proper installation shall be kept by the site manager or his representative.

(5) The records shall be available at the construction site during the construction period and shall be handed over to the construction site supervisor upon request. Like the delivery notes, they shall be kept by the company for a minimum of five years after completion of the project.

4.3 Declaration of conformity for the execution on the site

(1) The attestation of the proper fastening of the solar system in conformance with the provisions of the *allgemeine bauaufsichtliche Zulassung* ('national technical approval') shall be provided by the installing company in accordance with section 4.1 (1) by means of a declaration of conformity based on the following checks:

- check of whether the construction products used comply with the provisions of this *allgemeine bauaufsichtliche Zulassung* ('national technical approval') as well as the marking specifications given in section 2.2.4
- inspection of the execution in accordance with section 4.2.

(2) The results of the checks shall be recorded and evaluated as well as documented at least through the submission of a production report following Annex 6 including the reports and checks listed therein.

(3) The records shall be available at the construction site during the construction period. They shall be kept by the company for a minimum of five years after completion of the project. Copies of the records shall be handed over to the client for inclusion in the construction project files and upon request presented to Deutsches Institut für Bautechnik, the supreme building supervisory authority and the inspection body.

(4) If the test results are unsatisfactory, the installation company shall immediately take the necessary measures to eliminate the defect. Construction products which do not meet the requirements shall be handled in such a manner that they cannot be confused with compliant products. After the defect has been remedied, the relevant test shall be repeated immediately - where technically practicable and necessary for demonstration that the defect has been eliminated.

5 Provisions for use and maintenance

5.1 General

(1) The operator of a solar installation shall monitor the system to ensure tightness and functionality of the waterproofing sheet and proper fastening. The operator of the solar installation shall prepare operating instructions for this purpose. In accordance with these operating instructions the operator of a solar installation shall arrange for inspection at specified intervals and document the results of the regular inspections as well as all results that deviate from these operating instructions.

(2) The operator of a solar installation shall be obliged to commission suitable companies authorised to repair the solar installation fastening system which were instructed accordingly by the approval holder to carry out this task.

(3) Unless otherwise specified below, DIN 18531-4¹² shall apply.

¹²

DIN 18531-4:2010-5

Waterproofing of roofs - Sealings for non-utilised roofs – Part 4: Maintenance

5.2 Inspection

The fastening structure, the roof surfaces and the connections and terminations shall be inspected by an expert. An inspection and maintenance agreement shall be signed for this purpose. The inspections shall be documented in writing. The report shall contain information about the identified defects, any necessary further preliminary investigations and the type and urgency of necessary maintenance measures. The inspection shall be carried out every five years.

5.3 Maintenance

(1) Maintenance comprises the following tasks:

- removal of dirt and unwanted vegetation, particularly in the region of the fastened plastic profile
- checking of the roof surface in terms of waterproofing function
- checking of the contact areas of the solar installation in terms of impermissible deformations (crushing of insulation)
- checking of the longitudinal weld seams for detachment between the sheet and the plastic profile
- checking of the anchoring of the mounting screws between the cross beams and the aluminium profile.

(2) Maintenance of the installation shall be carried out twice a year by the operator.

(3) Minor repairs shall be carried out within the scope of maintenance.

Gerhard Breitschaft
President

Beglaubigt

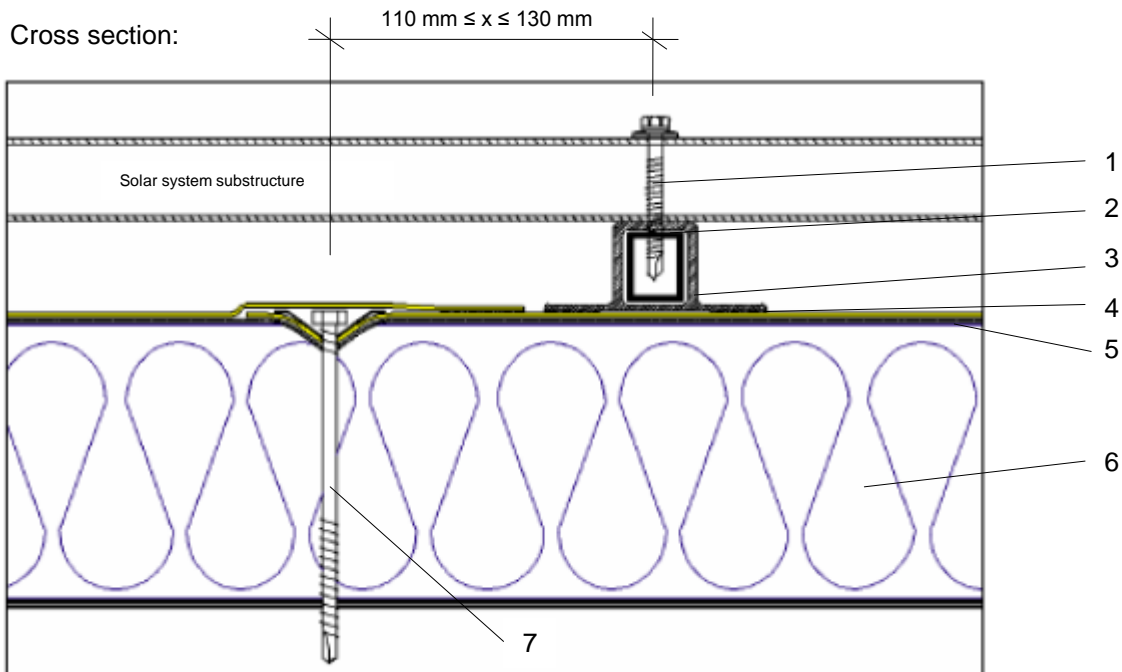

1. Solar module mounting screw (part of the fastening system)
2. Aluminium profile (part of the fastening system)
3. Plastic profile (part of the fastening system)
4. Welded joint between plastic profile and waterproofing sheet
5. ALKORPLAN F 35176 waterproofing sheet
6. Insulation product
7. Fastener of the waterproofing sheet

Overview of complete solar system including substructure:

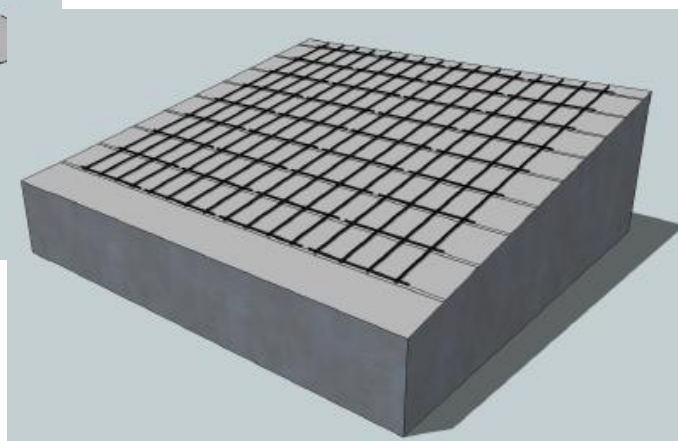
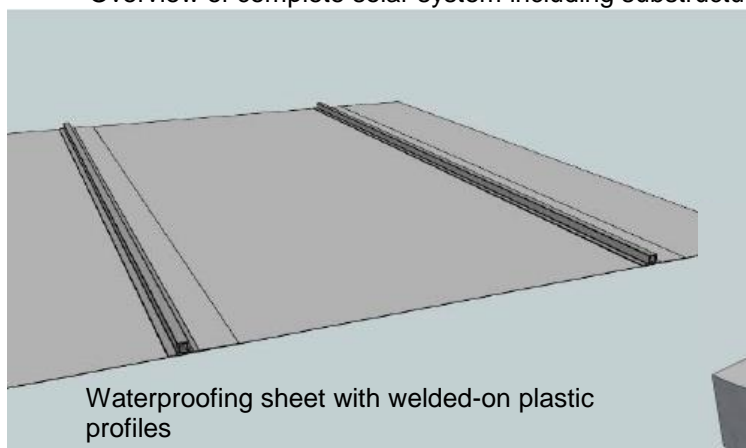

RENOLIT-ALKORSOLAR fastening system for solar panels for use on ALKORPLAN F 35176 waterproofing sheets

System design

Annex 1

Special requirements for waterproofing sheetr used as a component of the substrate (roof structure) for fastening solar systems:

ALKORPLAN F 35176	Test method	Units	Value
Thicknesses	DIN EN 1849-2	mm	1.5 -5% / +10%
			1.8 -5% / +10%
			2.0 -5% / +10%
Masses per unit area	DIN EN 1849-2	g/m ²	1850 -5% / +10%
			2200 -5% / +10%
			2350 -5% / +10%
Characteristic tensile strength R _k	DIN EN 12311-2	N/50 mm	1034
Expansion characteristics	DIN EN 12311-2 (A)	%	≥ 15
Characteristic joint peel strength R _k	DIN EN 12316-2	N/50 mm	364
Joint shear strength	DIN EN 12317-2	N/50 mm	≥ 800
Resistance to tearing	DIN EN 12310-2	N	≥ 180
UV resistance	DIN EN 1297 5000 h	./.	passed
Folding at low temperatures	DIN EN 495-5	°C	< -25
Characteristic peel strength R _k between waterproofing sheetr and plastic profile	DIN EN 12316-2	N/50 mm	507

Verification of resistance to external fire performance shall be demonstrated for the respective roof structure with an *allgemeines bauaufsichtliches Prüfzeugnis* ('national test certificate') in accordance with the *Bauregelliste* (Construction Products List) A, part 3, no. 2.8 or a classification report in accordance with EN 13501-5 with classification B_{Roof}(t1).

Overlap at the joint:

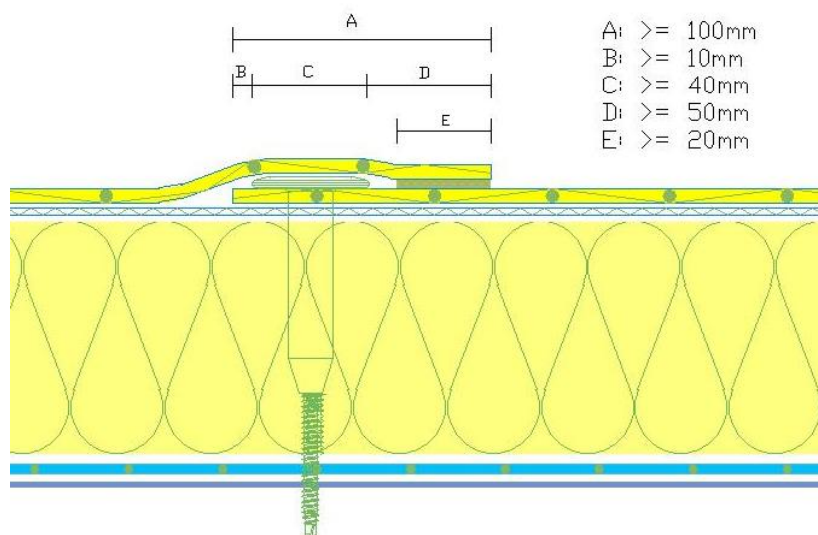

RENOLIT-ALKORSOLAR fastening system for solar panels for use on ALKORPLAN F 35176 waterproofing sheets

ALKORPLAN F 35176 waterproofing sheet characteristics

Annex 2

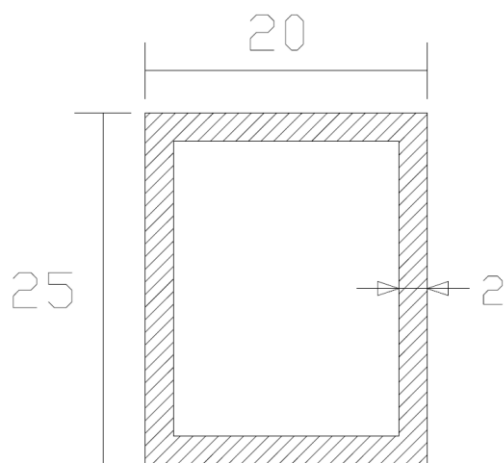

Figure 1: Aluminium profile

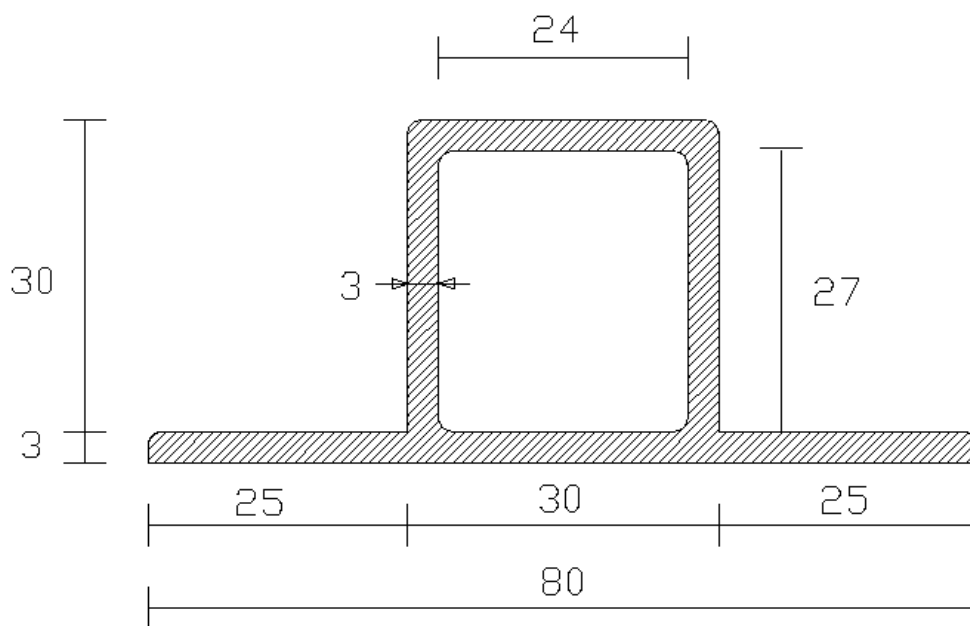

Figure 2: Alkorplan 81600 plastic profile

RENOLIT-ALKORSOLAR fastening system for solar panels for use on ALKORPLAN F 35176 waterproofing sheets	Annex 3
Dimensions and properties of components	

No.	Component	Requirement
1	Mounting screw	EJOT JT3-2-6.0 mounting screw with an <i>allgemeine bauaufsichtliche Zulassung</i> ('national technical approval') in accordance with Z-14.4-426 with a diameter of 6.3 mm and a length of 25 mm in accordance with the specifications given in this approval. Moreover the technical building provisions of <i>allgemeine bauaufsichtliche Zulassung</i> (national technical approval') no. Z-30.3-6 shall apply in relation to the corrosion protection.
2	Aluminium profile	The requirements of the approval holder as well as this approval shall be taken into account.
3	Plastic profile	The characteristic value R_k of the vertical force is 24.4 kN/m.
4	Insulation product	In accordance with the planner's compressive strength requirements
5	Fastener of waterproofing sheet	Fastening elements with an <i>allgemeine bauaufsichtliche Zulassung</i> ('national technical approval') or European Technical Approval or European Technical Assessment in accordance with the specifications of this approval as well as the requirements of the approval holder The stress plates must exhibit the following minimum dimensions: 80 mm x 40 mm
6	Waterproofing sheet	ALKORPLAN F 35176 in accordance with DIN EN 13956 with main characteristics as specified in Annex 2

RENOLIT-ALKORSOLAR fastening system for solar panels for use on ALKORPLAN F 35176 waterproofing sheets

Materials, characteristics, requirements

Annex 4

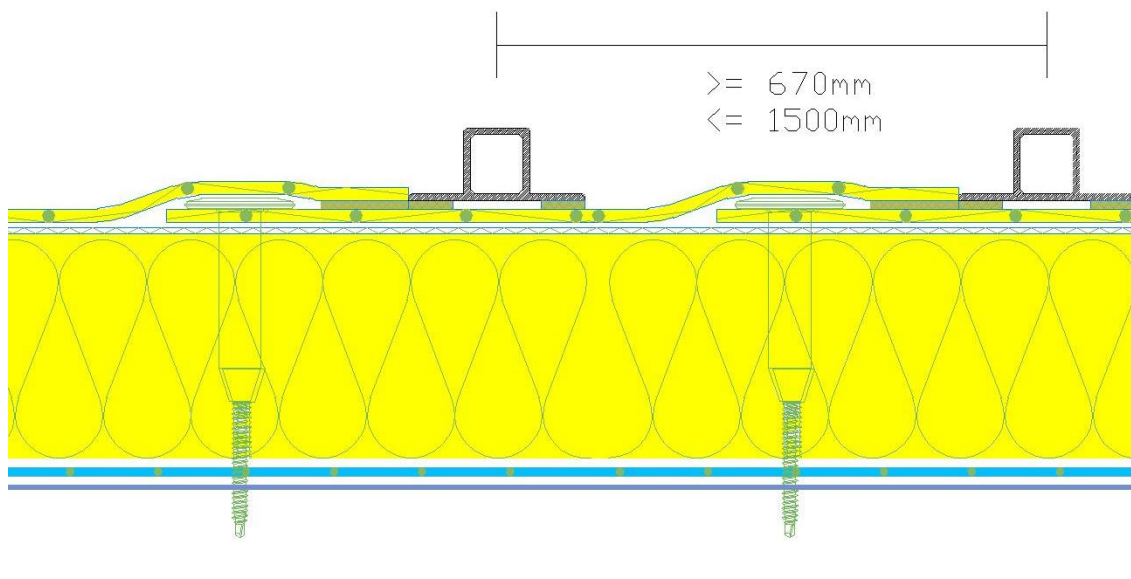

Minimum and maximum spacings between plastic profiles

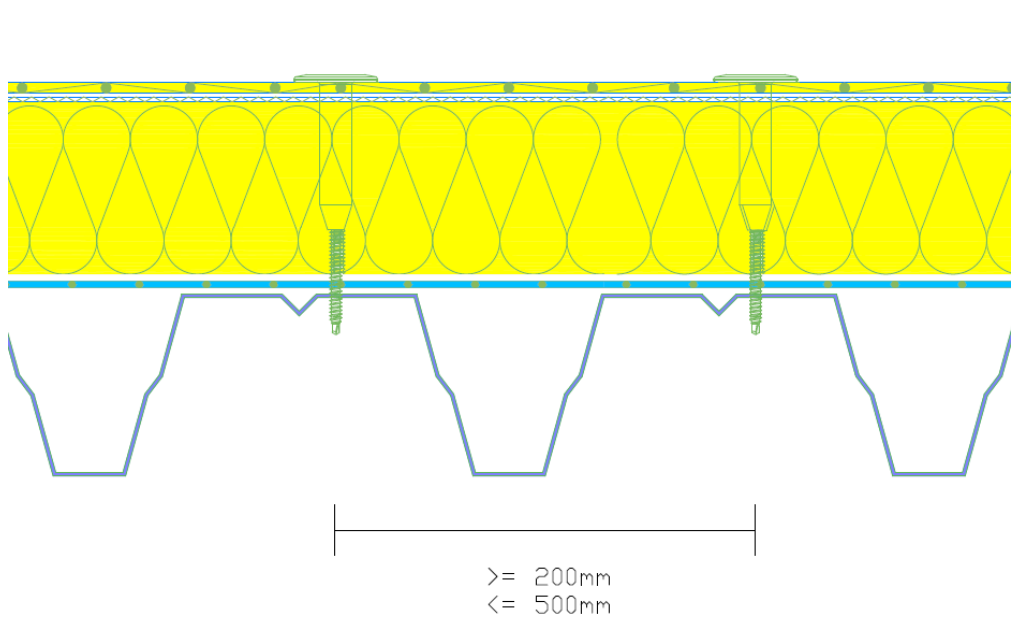

Minimum and maximum spacings between fasteners (in line with the plastic profile)

RENOLIT-ALKORSOLAR fastening system for solar panels for use on ALKORPLAN F 35176 waterproofing sheets

Arrangement of and spacings between fasteners and plastic profiles

Annex 5

	Test method	Frequency of		Value / Tolerance
		Factory production control (FPC)	External surveillance (ES)	
Inspection of incoming materials				
Aluminium profile				
Material	DIN EN 10204	Each delivery	2 per year	Works test certificate 3.1
Dimensions	DIN EN 12020-2	Each delivery	2 per year	Works test certificate 3.1, annex 3, figure 1
Plastic profile				
Starting materials	DIN EN 10204	Each delivery	2 per year	Works test certificate 3.1
Inspection after production				
Visible defects	DIN EN 1850-2	Every 288 m	2 per year	None
Mass per unit area	DIN EN 1849-2	Every 288 m	2 per year	≥ 675 g/30 cm -5% / +10%
Dimensions	DIN EN 1848-2	Every 288 m	2 per year	Annex 3, figure 2 -1/+2 mm
Thickness	DIN EN 1849-2	Every 288 m	2 per year	3 mm -0.1/+0.2 mm
Profile length	DIN EN 1848-2	Every 288 m	2 per year	3025 mm -10/+15 mm
Dimensional stability of profile	DIN EN 1107-2	Every 288 m	2 per year	Dimensions +/- 2%
Tensile and elongation characteristics	DIN EN 12311-2	Every 288 m	2 per year	Longitudinal: ≥15 N/mm ² ≥ 250% Transverse: ≥11 N/mm ² ≥ 250%
Peel strength between roofing membrane and plastic profile	EN 12316-2	2 per year	2 per year	Annex 2, table 2

RENOLIT-ALKORSOLAR fastening system for solar panels for use on ALKORPLAN F 35176 waterproofing sheets

Factory production control and external surveillance

Annex 6

Consecutive no.	Confirmation by the executing company	
1.	Project description: Location: Size:.....Building height:.....	
2.	Description of solar system:	
3.	Description of substrate, name of insulation product:	
4.	Approval: No.:..... from (date)	
5a	Structural analysis and installation plan: (Installer)	
5.b	Executing company:..	
5.c	Construction period:	
		Confirmation
6.	The specialised staff of the executing company has been informed of the proper processing by the approval holder	
7.	Evaluation prior to installation of plastic profiles	
	a)	Roofing membrane requirements as per approval
	b)	Compressive strength of insulation material as per structural design specifications
	c)	Roof slope
	d)	Type and arrangement of fasteners as per structural analysis
8.	Control of the installation	
	a)	Reports on weather conditions
	b)	Reports on material consumption are available
	c)	Visual inspection
	d)	other
	e)	
Comments:		
RENOLIT-ALKORSOLAR fastening system for solar panels for use on ALKORPLAN F 35176 waterproofing sheets		Annex 7
Declaration of conformity template		